

PFISTERER

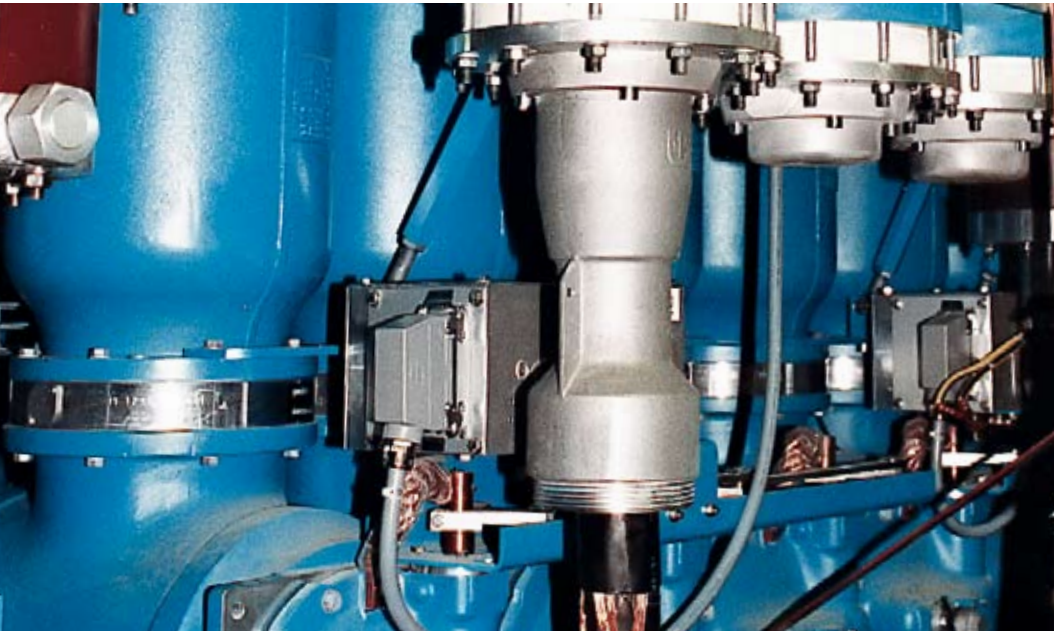

MV-CONNEX, HV-CONNEX, IXOSIL Terminations, IXOSIL Slip-on Joints

CABLE SYSTEMS

Accessories and Systems for Medium and High-Voltage Cables up to 300 kV.

THE POWER CONNECTION

CABLE SYSTEMS | COMPONENTS | OVERHEAD LINES | RAILWAY CATENARY SYSTEMS

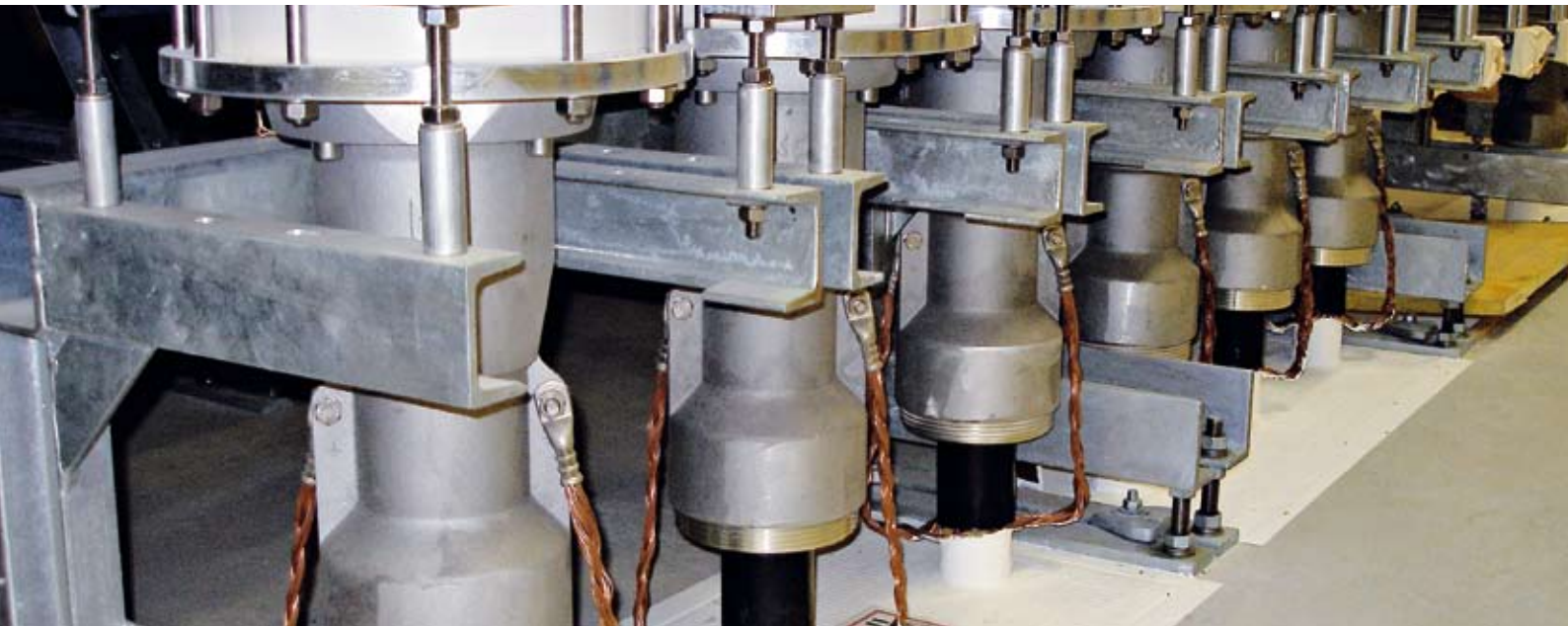

Welcome to the **CABLE SYSTEMS** Centre of Competence.

Our range of cable accessories offers solutions for virtually all applications in the area of medium and high-voltage engineering up to 300 kV. All accessories use silicone rubber as insulating medium because of its outstanding properties. We offer components and complete systems, as well as worldwide installation and advisory services.

CONNEX. A Dry, Separable Connector System for Medium and High-Voltage Networks.

CONNEX meets all your requirements to an universal system of separable connectors: fully insulated with metal housing and providing touch-proof properties. It is maintenance-free, suitable for outdoor use and waterproof. This means CONNEX can be used even in the most extreme conditions.

MV-CONNEX for medium voltage systems comes in a wide range of variations. It includes traditional plug and socket combinations, multiple sockets, busbar connectors, surge arresters and voltage detectors. HV-CONNEX components for high-voltage systems up to 245 kV are factory tested and are surprisingly simple to install. Complex oil and gas work during installation and commissioning of transformers is finally a thing of the past.

IXOSIL Cable Terminations.

The comprehensive range of terminations suits all applications: the use of silicone rubber as the insulating medium means they are ideally suited to outdoor use, and special designs for indoor use are available as well. In addition, oil-filled and dry models are also available. Standard components with porcelain insulators complete the range.

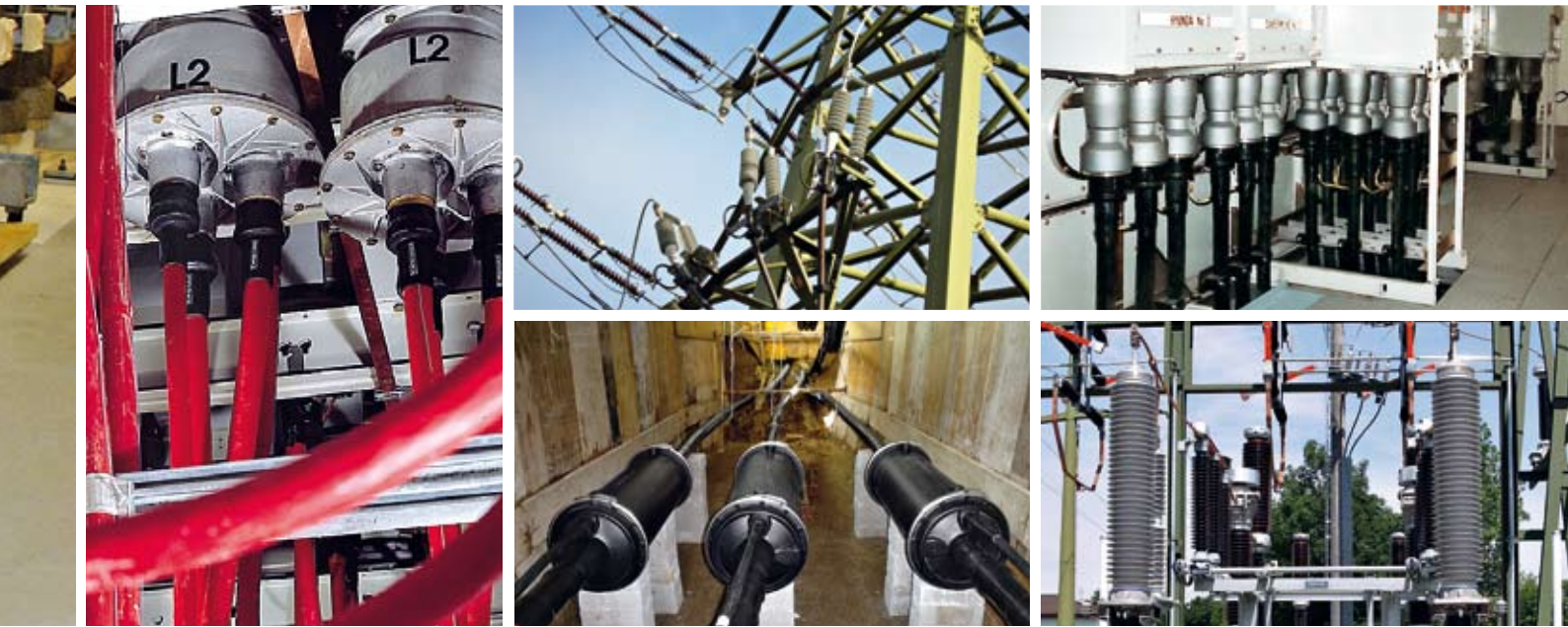

IXOSIL Slip-on Joints.

IXOSIL silicone-rubber joints can be used to join all XLPE and EPR insulated cables within the 72.5 kV to 300 kV voltage range. There are two designs: the compact, one-piece version and a threepart version for connecting cables of different types and diameters.

IXOLINE. Factory-Assembled Cables Ready-to-Use.

IXOLINE cable links are supplied with IXOSIL or CONNEX terminations. No special tools are required for installation. Result: increased efficiency in less time and at lower cost.

Silicone – a Key Material in High-Voltage Engineering.

Water, dirt, grease and oil-resistant, completely maintenance-free, shock-resistant and unbreakable: silicone rubber is the perfect material for cable terminations and far superior to traditional materials such as porcelain. When used as a stress-relief device in sealed applications, silicone evens out temperature variations and unevenness in the cable surface much better than harder materials such as EPDM do. Dangerous partial discharges caused by air gaps are safely avoided. PFISTERER makes silicone products primarily using advanced LSR (Liquid Silicone Rubber) designs; special variations are designed using RTV (room-temperature vulcanising silicone).

Worldwide Installation Services.

The installation of high-voltage components requires knowledge and care. We share our know-how in practical applications training courses. If requested we can of course carry out the installation by ourselves for you, wherever in the world you may be.

Cable Systems | Medium-Voltage



MV-CONNEX 10 kV – 52 kV

The MV-CONNEX range is ideal for use in ring main units, circuit-breaker switch-gear, high-voltage motors, transformers, capacitors, transducers and sealing boxes. The connectors on the equipment-side are designed to meet EN 50180, 50181, and DIN 47637. The plug is suitable for all kinds of insulated plastic cables. As well as a wide range of standard types there are also customer-specific versions for every cable type. The MV-CONNEX system features numerous variations: in addition to the standard plug and socket combination, there are many other versions for testing purposes and special applications.

Advantages

- no liquid insulating medium
- no need to open the cable termination at the installation site
- deckwater-proof
- suitable for outdoor use
- thorough transformer and GIS testing by manufacturer possible

A Contact system

- 1 contact ring
- 2 tension cone
- 3 thrust piece

B Insulating and field-control part

C Housing

- 4 bell flange
- 5 pressure sleeve
- 6 pressure spring
- 7 heat-shrink
- 8 test lead (depends on design)
- 9 cable screen

D Bushing

- 10 female contact part
- 11 insulating bushing
- 12 housing

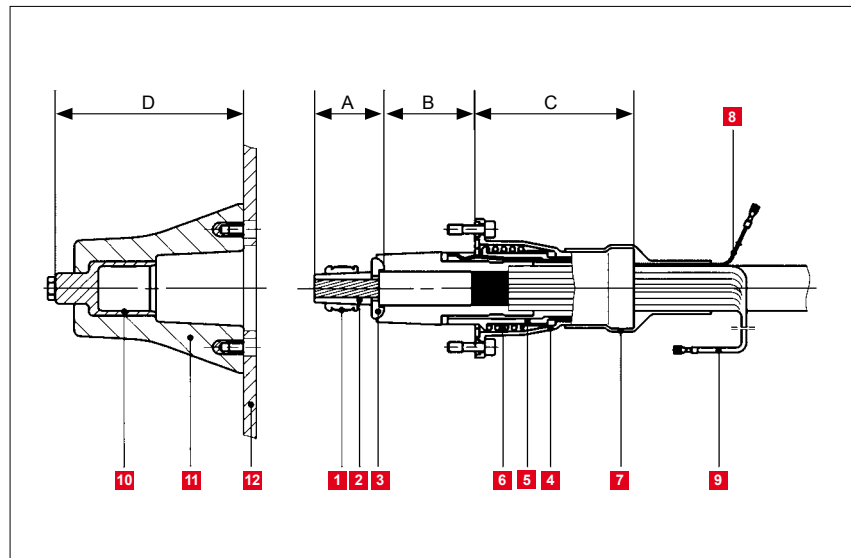

Test standard: DIN VDE 0278 Part 6
high-current design II

CONNEX cable connector system

		Size				
		0	1	2	3	3-S
Current rating	I_N (A)	250	630	800	1250	1250
Max. working voltage	U_m (kV)	24	36	42	42	52
AC voltage test	50 Hz/1 min (kV)	50	70	95	95	117
Nominal withstand lightning impulse voltage	1.2/50 μ s (kV)	125	170	200	200	250
Partial discharg	$2 \times U_o$ (pC)	≤ 10	≤ 10	≤ 10	≤ 10	≤ 10
DC voltage test	15 min $6 \times U_o$ (kV)	72	108	125	125	156
Rated short-time withstand current	0.5 sec (kA)	-	50	50	63	63
Rated short-time withstand current	1 sec (kA)	16	31.5	40	50	50
Nominal impulse current	(kA)	40	125	125	150	150

MV-CONNEX Multi-Contact Elbow Bushing 24 kV – 52 kV

Multi-contact elbow bushings are used instead of DIN-standard porcelain versions on the medium-voltage side of power transformers. They distribute the current over two or four cables, thus accommodating higher power loads using more manageable cable cross sections.



MV-CONNEX Surge Arrester 6 kV – 52 kV

CONNEX surge arresters are used to protect metal-enclosed switchgear fitted with cable terminations in accordance with EN 50180/EN 50181. The surge arresters are connected to the switchgear transformer and prevent the entry of excessively high surges. The surge arresters are particularly effective in limiting surges caused by reflected travelling waves and switching overvoltages.



MV-CONNEX Busbar Connectors 24 kV – 42 kV

Busbar connectors facilitate the modular construction and on-site expansion of SF₆ insulated switchgear, because the gas compartment does not have to be opened during installation. The range includes 24 kV to 42 kV versions.



CMA-MV-CONNEX Motor Connector

The CMA-MV-CONNEX motor connector allows the quick and easy connection of high-voltage motors, with the connection area being fully metal-enclosed and intrinsically safe. The system is easily installed in place of the motor connection box.

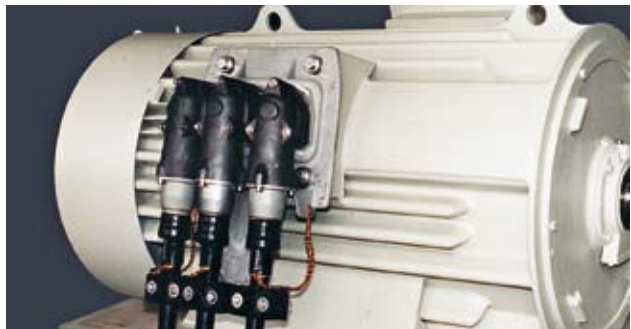

Voltage Detecting Systems

The integrated capacitive potential point makes it easy to check the connection for the absence of voltage. The PFISTERER range includes mobile and stationary continuous voltage indicators, as well as phase comparators and performance testing equipment.



Cable Systems | High-Voltage



HV-CONNEX 72.5 kV – 245 kV

The advantages of the CONNEX system come to the fore in particular in the area of high-voltage systems: simple on-site installation and factory-tested components save money and provide additional safety. Plug-in HV-CONNEX systems make costly oil and gas work during the installation and commissioning of transformers and gas-insulated switchgear a thing of the past. Thanks to their plug-in connectors, cable joints from the HV-CONNEX range are much more flexible than traditional solutions when it comes to building and converting electrical systems. Needless to say, the range includes all the connection components needed to test the system and the attached equipment.

Advantages

- approx. 50 % shorter mounting length compared with conventional systems in accordance with IEC 60 859 and 62271-209
- no opening of the cable termination and associated costly gas or oil work
- horizontal, vertical and angled versions for connection to GIS and transformers
- considerably reduced installation times
- the use of pre-assembled and tested components means maximum safety and efficiency
- installation errors are minimised
- if a fault does arise, rapid separation of cable and equipment

A Bushing

- 1 female contact part
- 2 insulating bushing
- 3 housing

B Contact system

- 4 contact ring
- 5 tension cone
- 6 thrust piece

C Insulating and field-control part

D Housing

- 7 pressure sleeve
- 8 pressure spring
- 9 bell flange
- 10 gasket
- 11 threaded counter ring
- 12 heat-shrink
- 13 cable screen

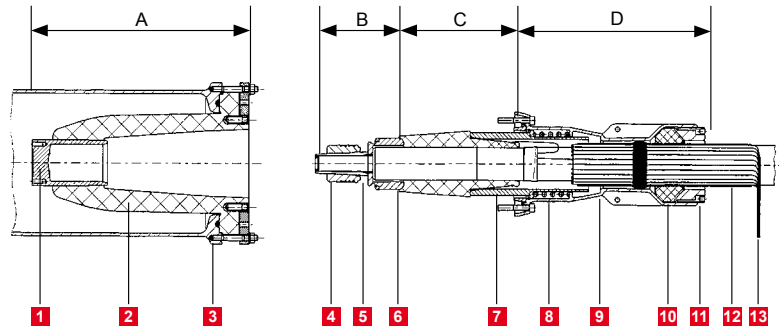

Sample drawing: Cable connecting System Size 5-S

Test standard: TNT 10.97		CONNEX cable connection system			
		Size 4	5-S	6	6-S
Current rating	I_N (A)	2500	2500	2500	2500
Max. working voltage	U_m (kV)	72.5	145	170	245
AC voltage test	50 Hz/1 min (kV)	140	275	325	460
Nominal withstand lightning impulse voltage	1.2/50 μ s (kV)	325	650	750	1050
Partial discharge	$2 \times U_o$ (pC)	≤ 2	≤ 2	≤ 2	≤ 2
DC voltage test	15 min $6 \times U_o$ (kV)	144	304	348	508
Nominal short-time current	0.5 sec (kA)	63	63	63	63
Nominal short-time current	1 sec (kA)	50	50	50	50
Nominal surge current	(kA)	160	160	160	160

GIS Equipment

HV-CONNEX bushings require less space than conventional type connectors. All well-known manufacturers have since begun to offer equipment which exploits this advantage. An extension adapter for conventional cable connector modules is required when HV-CONNEX is used with traditional GIS equipment.



Transformers

The installation of two connectors on the equipment makes it possible to have one cable connector on the side, facing down. If it is necessary to connect this kind of transformer using an overhead line, an HV-CONNEX plug-in insulator for overhead lines can be installed and the downward facing cable connector then terminated with a dummy connector. This plug-in insulator also makes it very easy to carry out simple voltage tests on transformers fitted with HV-CONNEX equipment connectors, either in the factory or on site.



Plug-in Joint Boxes

The HV-CONNEX cable connection system means plug-in joint boxes for various geometric configurations can be assembled using fewer components. The advantage of these joint boxes is that the joint body is a single unit which is completely manufactured and tested at the factory. Solutions of this kind bring enormous benefits if, for example, cables need to be bent back multiple times during the installation and conversion phase.



CONNEX 170 kV Plug-in Bushing

The HV plug-in bushing can be used wherever high-voltage equipment needs to be connected to overhead lines. A CONNEX plug-in bushing provides the connection to the equipment. If the plug-in bushing is used, the high-voltage equipment can be operated immediately without having to open and test it again at the installation site. In addition, plug-in HV versions can be installed at any angle. And the bushing can, of course, be swapped for a cable connector at any time.



The conventional alternative: IXOSIL ESG and IXOSIL ESU

IXOSIL ESG and IXOSIL ESU also provide conventional terminations in accordance with IEC ESG: IEC 60840, 60859, 62271 and ESU: IEC 60840, EN 50299 for the direct introduction of XLPE insulated high voltage cables in oil- or gas-insulated equipment. For IXOSIL ESU we offer customized adapters. Both types are available in vertical, horizontal or overhead versions from 72,5 kV to 170 kV.



Cable Systems | High-Voltage



IXOSIL Outdoor Cable Termination (Composite)

Type ESS terminations are available for voltages from 72,5 kV to 300 kV with various creepage distances. A resin-glass fibre tube equipped with silicone sheds gives the ESS termination the highest mechanical strength. The ESS termination can withstand the effects of high forces – in a shortcircuit for example. Insulation within the resin-glass fibre tube is ensured by a filling compound. An easy-to-fit head fitting completes the ESS to provide a maintenance-free system.

Highest voltage	U _m (kV)	72,5	123	145	170	245	300
Standards		IEC60840	IEC60840	IEC60840	IEC60840	IEC62067	IEC62067
		IEC60815	IEC60815	IEC60815	IEC60815	IEC60815	IEC60815
Rated voltage	U (kV)	60 – 69	110 – 115	132 – 138	150 – 161	220 – 230	275 – 287
Lightning impulse withstand voltage (BIL)	(kV)	325	550	650	750	1050	1050



IXOSIL Outdoor Cable Termination (Porcelain)

The ESP termination can be supplied for voltages from 72,5 kV to 300 kV. The stress cone of the ESP and the ESS termination is identical. Specifications mentioned for ESS are valid as well.

Highest voltage	U _m (kV)	72,5	123	145	170	245	300
Standards		IEC60840	IEC60840	IEC60840	IEC60840	IEC62067	IEC62067
		IEC60815	IEC60815	IEC60815	IEC60815	IEC60815	IEC60815
Rated voltage	U (kV)	60 – 69	110 – 115	132 – 138	150 – 161	220 – 230	275 – 287
Lightning impulse withstand voltage (BIL)	(kV)	325	550	650	750	1050	1050



IXOSIL Flexible Outdoor Cable Termination

Type ESF flexible terminations are dry, slip-on terminations for modular assembly. The use of silicone sheds makes them ideally suited for applications in outdoor installations. Type ESF terminations are available for voltages from 52 kV to 145 kV.

Highest voltage	U _m (kV)	52	72,5	123	145
Standards		IEC60840	IEC60840	IEC60840	IEC60815
		IEC60815	IEC60815	IEC60815	
Rated voltage	U (kV)	45 – 47	60 – 69	110 – 115	132 – 138
Lightning impulse withstand voltage (BIL)	(kV)	250	325	550	550

IXOSIL Outdoor Cable Termination (Dry Type)

Type EST is ideally suited for out- and indoor. It is available for voltages from 72,5 kV to 145 kV and consists of one flexible termination of type ESF and with one or three supporting insulators, depending on the operating voltage. It is free from liquid insulating materials, can be installed in each position and is self-supporting. The EST is built up modular which permits a fast and simple installation. There is no need for a special platform for fitting the terminations, just a protection against wind and weather. The baseplate is dedsigned to fit on several existing support structures without any problems.



Highest voltage	U_m (kV)	72,5	123	145
Standards		IEC60815 IEC60840	IEC60815 IEC60840	IEC60815
Rated voltage	U (kV)	60 – 69	110 – 115	132 – 138
Lightning impulse withstand voltage (BIL) (kV)		325	550	550

IXOSIL Flexible Indoor Cable Termination

Type ESK terminations are dry, slip-on terminations for modular assembly. The use of silicone sheds makes them ideally suited for applications in indoor installations. Type ESK terminations are available for voltages of 52 kV and 72,5 kV.



Highest voltage	U_m (kV)	52	72,5
Standards		IEC60815	IEC60815
Rated voltage	U (kV)	45	60
Lightning impulse withstand voltage (BIL) (kV)		250	350

Cable Systems | High-Voltage



IXOSIL Slip-on Joints

IXOSIL slip-on joints essentially consist of premoulded slip-on silicone parts. This enables the secure and efficient connection of two polymeric-insulated cables (XLPE, EPR). The proven slip-on technique ensures minimum installation time and a maximum operation reliability. The tested and applied material complies with all electrical, mechanical and thermal requirements for rebuilding the insulation of a cable. IXOSIL slip-on joint is available in one-piece and threepart set up and it may be used for connection of copper as well as aluminium cables. Both joints are available in different variants.









IXOSIL One-Piece Slip-on Joints

The one-piece slip-on joints are available for voltages from 72,5 kV to 300 kV. Due to the one-piece construction the joints are extremely compact in size. The space required in a joint bay therefore is reduced to a minimum. Each size of the silicone body covers a range of different insulation diameters.



IXOSIL Threepart Slip-on Joint

The threepart slip-on joint is available for voltages from 72,5 kV to 170 kV. The well-ried threepart construction of this joint enables cables of different types and dimensions to be connected. For example a 630 mm² EPR cable can be connected to a 500 mm² XLPE cable.

Joint Types	MSA DO	MSA S	MSA MS
			
	Screen transition	Shrink sleeve	Metal water barrier with shrink sleeve
Joint Types	MSA XL or XK	MSA G	MSA MG
			
	Screen interruption with screen take out	Plastic casing with filling compound	Metal water barrier with plastic casing

Highest voltage	Standards	Rated voltage	Lightning impulse withstand voltage (BIL)	Partial discharge measurement	Conductor cross section	Diameter over cable insulation (prepared)	Net weight approx.
U _m (kV)		U (kV)	(kV)	(pC)	(mm ²)	(mm)	(kg)
72,5	IEC60840	60 – 69	325	< 5	150 – 1200	37 – 87	72 – 90
123	IEC60840	110 – 115	550	< 5	240 – 2000	45 – 103	50 – 130
145	IEC60840	132 – 138	650	< 5	240 – 2000	45 – 103	80 – 160
170	IEC60840	150 – 161	750	< 5	240 – 2000	45 – 103	80 – 160
245	IEC62067	220 – 230	1050	< 5	240 – 2000	69 – 102	80 – 200
300	IEC62067	275 – 287	1050	< 5	240 – 2000	69 – 102	80 – 220

Installation and Accessories

IXOLINE – Ready-Made Cable Systems

A PFISTERER specialty: IXOLINE – ready-made cables with dry IXOSIL or CONNEX connectors. IXOLINE components make it very easy to assemble short cable connections. The applications are endless:

- for turn key substations
- for emergency cable connections
- for cables under roads and rail lines
- for short connections between GIS and/or transformers
- for connecting overhead switchgear
- for high-voltage test cables



Installation Made Easy

The installation of high-voltage components requires know-how and care. Our own team of technicians carries out the installation of cable equipment, cable runs, cabling of substations and testing throughout the world in the area of medium and high-voltage. We also use practical oriented training courses and on-site supervision to share the necessary know-how.



Tools

We can supply all the tools and components needed for the installation and testing of high-voltage connectors. We can also advise on your earthing concept and provide the required accessories.



High-Voltage Lab

Our high-voltage lab in Altdorf is equipped for internal and external testing. All tests are carried out in accordance with the relevant standards. Aside from type acceptance and routine tests, we also provide testing of fittings and cable systems. Much of our laboratory resources are dedicated to research and development in order to ensure that our products meet the latest market requirements. The infrastructure consists mainly of:

- AC test equipment up to 1000 kV
- Impulse voltage generator up to 1600 kV
- Current inducing system for heat cycle test
- Artificial rain test equipment
- Fully shielded PD measurement room



PFISTERER worldwide

PFISTERER

Kontaktsysteme GmbH & Co. KG

Rosenstraße 44
73650 Winterbach

Germany

Phone +49 (0) 7181 7005 0
Fax +49 (0) 7181 7005 565
E-mail dialog@pfisterer.de

PFISTERER IXOSIL AG

Gotthardstrasse 31
6460 Altdorf

Switzerland

Phone +41 (0) 41 874 75 75
Fax +41 (0) 41 874 75 76
E-mail power@ixosil.ch

PFISTERER S.A.

Av. Velez Sarsfield 464
C1282AFR Buenos Aires

Argentina

Phone +54 (0) 11 4306 3595
Fax +54 (0) 11 4362 2381
E-mail pfisterer@pfisterer.com.ar

PFISTERER Ges.m.b.H.

Augasse 17
1090 Wien

Austria

Phone +43 (0) 1 3176531 0
Fax +43 (0) 1 3176531 12
E-mail info@pfisterer.at

PFISTERER Ltda.

Rua Frei Caneca, 30, sl. 01/02
06706 015 Cotia, São Paulo

Brazil

Phone +55 (0) 11 4612 9733
Fax +55 (0) 11 4612 3856
E-mail pfisterer@pfisterer.com.br

PFISTERER

Representative Office

Unit 520, Landmark Tower 2
8 North Dongsanhuan Road
Chaoyang District
100004 Beijing

China

Phone +86 10 6590 6272
Fax +86 10 6590 6105
E-mail info.cn@pfisterer.com

PFISTERER

Representative Office

Room 2606, 26/F., Paul Y. Centre
51 Hung To Road
Kwun Tong, Kowloon

Hong Kong, China

Phone +852 2687 2826
Fax +852 2688 0663
E-mail info.hk@pfisterer.com

PFISTERER spol.s.r.o.

Jindřišská 273
Zelene Pedmestí
53002 Pardubice

Czech Republic

Phone +420 (0) 466 657490
Fax +420 (0) 466 613581
E-mail dialog@pfisterer.cz

PFISTERER Sàrl.

35 avenue d'Italie
BP 10045
68311 Illzach Cedex

France

Phone +33 (0) 389 319029
Fax +33 (0) 389 319028
E-mail info@pfisterer.fr

PFISTERER

Handelsgesellschaft mbH

Rosenstraße 44
73650 Winterbach

Germany

Phone +49 (0) 7181 7005 301
Fax +49 (0) 7181 7005 333
E-mail handel@pfisterer.de

PFISTERER Kereskedelmi Kft.

Gyarmat u. 67/C
1147 Budapest

Hungary

Phone +36 (0) 1 2513441
Fax +36 (0) 1 2511713
E-mail office@pfisterer.hu

PFISTERER s.r.l.

Via Sirtori 45 d
20017 Passirana di Rho (MI)

Italy

Phone +39 02 93158 11
Fax +39 02 93158 27
E-mail pfisterer@pfisterer.it

PFISTERER Sp. z o.o.

Ul. Poznanska 258
05-850 Ozarów Mazowiecki

Poland

Phone +48 (0) 22 72241 68
Fax +48 (0) 22 72127 81
E-mail info@pfisterer.pl

PFISTERER AB

Flygfältsgatan 2
12822 Skarpnäck

Sweden

Phone +46 (0) 8 7240 150
Fax +46 (0) 8 6054 750
E-mail info.se@pfisterer.com

PFISTERER

Representative Office

187 Tanjong Rhu Road
08-16 Sanctuary Green
Singapore 436925

Singapore

Phone +65 6346 4042
Fax +65 6346 7110
E-mail info@pfisterer.sg

PFISTERER (Pty.) Ltd.

9 Willowton Road
Pietermaritzburg 3201

South Africa

Phone +27 (0) 33 397 5400
Fax +27 (0) 33 387 6377
E-mail info@pfisterer.co.za

PFISTERER UPRESA S.A.U.

Calle Industria 90-92
08025 Barcelona

Spain

Phone +34 (0) 93 4367409
Fax +34 (0) 93 4367701
E-mail pfisterer.upresa@pfistererupresa.eu

PFISTERER SEFAG AG

Werkstrasse 7
6102 Malters, Luzern

Switzerland

Phone +41 (0) 41 4997 272
Fax +41 (0) 41 4972 269
E-mail connect@sefag.ch

PFISTERER INTERNATIONAL AG

Werkstrasse 7
6102 Malters, Luzern

Switzerland

Phone +41 (0) 41 4997 474
Fax +41 (0) 41 4973 473
E-mail export@sefag.ch

PFISTERER

Representative Office

PO Box 184090
Gate 7, Floor 3
Hamarain Center
Dubai

United Arab Emirates

Phone +971 4 2690147
Fax +971 4 2690148
E-mail info@pfisterer.ae

PFISTERER Ltd.

29 Pillings Road
Oakham LE15 6QF

United Kingdom

Phone +44 (0) 15 7277 1300
Fax +44 (0) 15 7277 1269
E-mail info.uk@pfisterer.com