

**CABUS and ASEPlas
CABLE CLAMPS & CLEATS**

INTERTECH



Intertech Engineering Pty Ltd

Contents

	Page
Introduction	1
Single Cable Clamps CABUS – Cast Alloy – 51 Series	2
Trefoil Fault Rated Clamps CABUS – Cast alloy – 54 Series	3
Single Cable Clamps CABUS – Cast Alloy – 2 bolt 58 and 59 Series	5
CABUS Special Cable Clamps For cable diameters 100 to 200mm +	6
Glass Reinforced Trefoil Cable Cleats Torgy ASEPlas	7
Glass Reinforced Single Cable Cleats (Surface Mount and Channel Mount) ASEPlas	8
Glass Reinforced Trefoil Cable Cleats ASEPlas	10
KOZ Polyamide Clamps	11
KOZ Single Way Clamps	12
KOZ Trefoil Clamps	14
KOZ Mounting Blocks	16



54 Series CABUS Clamp

Intertech Engineering

Formed in 1995, Intertech Engineering has fast developed a reputation for customer service in the electrical industry.

In an industry driven by engineering excellence and providing the right solution, at the right price, first time, Intertech Engineering is aware of the pressure that both local and global companies are under to achieve world's best standards in quality solutions in both competitiveness and delivery.

Intertech Engineering offers support and design assistance in the design and application of products for the electrical industry. Intertech Engineering does not just supply products, it supplies solutions.



58 Series CABUS Clamp



59 Series CABUS Clamp

CABUS Cable Clamps

The way cables are fixed into place is very important.

Poor clamping can damage the cable or put undue strain on cable terminations or onto the cable conductors, sheathing and insulation.

Fault currents in Trefoil cable systems can only be properly controlled by the use of tested fault rated cable clamps.

For data and communications cables, secure and easy to use cleats ensure rapid, damage free installation.

All cables from data & communications to LV, HV and EHV have special

clamping requirements to ensure easy installation and the safe and long term performance of the cable system.

Intertech is a major manufacturer and supplier of cable clamps to projects in Australia, NZ and SE Asia. Our expert staff have many years of experience in the design and manufacture of quality Cabus cable clamps.

Intertech offers a complete range of clamps and cleats for all cable types and applications.

Whatever your clamping needs, we provide specialist advice, high quality products and fast and efficient service.

Cast Aluminium Single Cable Clamps – 51 Supergrip Series

The Cast Aluminium Supergrip Series clamps are designed for use in high rise buildings, shafts and tunnels. The unique interlocking design of the base and top prevents the clamp opening under axial cable forces. Features include:

- ✓ The top to base interlock relieves bending stress on the fixing bolt and allows a higher clamping force without kinking or pinching the cable.
- ✓ The base fits into standard mounting channels and provides automatic alignment and prevents twisting under load.
- ✓ Self aligning, compact design makes installation quick, simple and positive.
- ✓ Non-magnetic for single core cables.

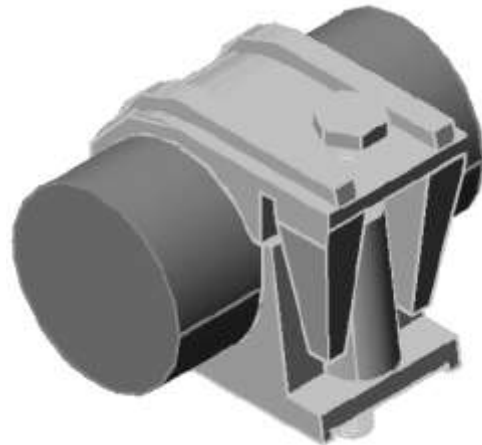

Clamp Dimensions

Clamp No.	Cable OD (D) (mm)	H (mm)	W (mm)	Bolt Diameter ¹ (B) (mm)
5125	19-25	31	41	10
5130	24-30	36	46	10
5135	29-35	41	51	10
5141	34-41	48	58	10
5147	40-47	54	64	10
5154	46-54	61	71	10

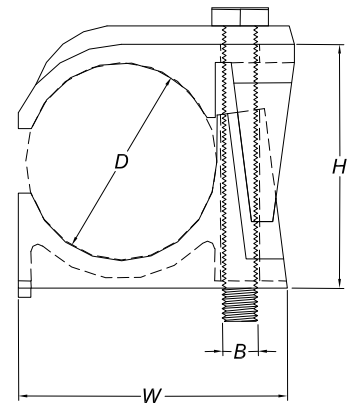

1 Fixing bolt supplied by customer

Neoprene Inserts (NI)

Due to the small size of these clamps, neoprene inserts are not available. The internal cable bearing surfaces are designed to prevent damage to the cable sheath.

Cast Aluminium Trefoil Cable Clamps – 54 Series

Cast Aluminium Trefoil Clamps are designed for strength and ease of installation and provide tested bursting strength cable fixing at economic prices. Features of the widely specified 54 series include:

- ✓ Cables can be laid directly onto the fixed bases – reducing cable installation time.
- ✓ Simple clamping with bolts which fit into side slots in base and top.
- ✓ Manufactured from silicone aluminium alloy AC601 which combines high strength, and outstanding corrosion resistance. Also available in manganese bronze.
- ✓ Designed and tested for high bursting strength ranging to over 20kN. Type test reports available upon request.
- ✓ Cable diameters outside those shown below can be accommodated by our design and build service.
- ✓ Neoprene inserts – designated NI after the clamp number – provide a compressible cable bearing surface.



Cast Aluminium Trefoil Cable Clamps – 54 Series

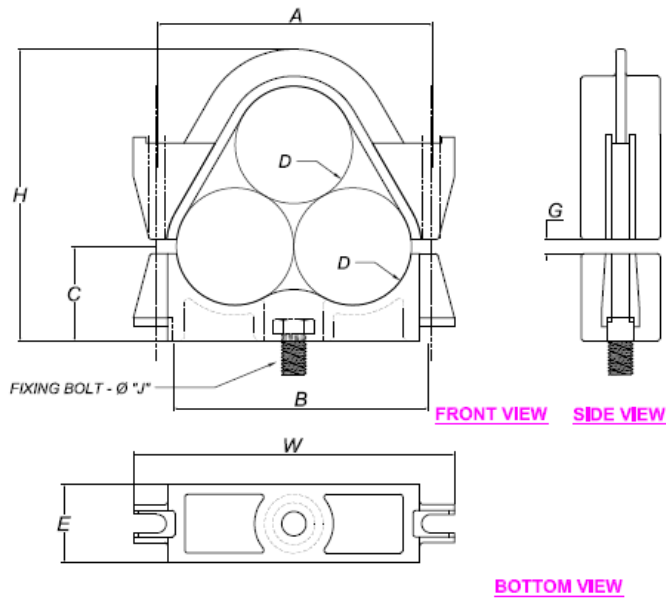

Clamp No.	Cable OD (mm)	A	B	C	E	G	H	Fixing Bolt ¹	Side Bolt ²	W
5420	19-20	58	73	16	35	4	51	3	M8	81
5427	25-27	68	80	22	38	5	71	3	M8	89
5429	27-29	70	80	22	38	5	73	3	M8	89
5435	33.5-35	87	76	30	38	5	97	M10	M8	108
5437	35-37	87	80	32	38	5	97	M12	M10	111
5440	38-40	98	88	35	40	6.5	104	M12	M10	118
5442	40.5-42.5	102	94	35	41	6.5	111	M12	M10	124
5448	46-48	113	104	40	45	6.5	122	M12	M10	134
5452	50-52	122	112	40	45	6.5	127	M12	M10	143
5454	52-54	126	116	42	45	6.5	131	M12	M10	148
5456	54-56	130	121	45	47	6.5	135	M12	M10	151
5459	56.5-59	130	121	45	48	6.5	137	M16	M10	152
5463	60-63	152	140	50	60	7	160	M16	M12	180
5467	64-67	160	148	53	60	7	167	M16	M12	188
5471	67-71	169	156	57	61	7	177	M16	M12	197
5478	75-78	182	170	58	62	7	187	M16	M12	212
5482	79-82	191	180	62	62	9.5	199	M16	M12	228
5488	84-88	202	190	66	65	10	201	M16	M12	235
5495	93-95	218	204	71	67	12	223	M16	M12	253

1 Fixing Bolt is customer supplied

2 Side bolts are supplied with all clamps except 5420, 5427 and 5429. Standard bolt type is 304 stainless steel.

Neoprene Inserts (NI)

Neoprene Inserts Available. Add NI to Clamp No. e.g. 5454NI

Standard NI insert is 3mm thick. Other sizes are available upon request.

Cable OD range is reduced by 3mm i.e. 5454 range becomes 49-51mm

Cast Aluminium Single Cable Clamps – 58/59 Series

Simple two-bolt fix and locate cable clamp suitable for either channel mount – 58 Series, or surface mount – 59 Series.

Channel mount interlocks with standard fixing channels.

Clamp Dimensions

Clamp No.	Cable OD (mm)	C (mm)	W (mm)	T (mm)	H (mm)	Fixing Bolt Length (mm)	Fixing Bolt Hole dia (mm)
5857	50-57	77	99	45	69	65	10
5864	56-64	84	106	45	76	70	10
5870	62-70	90	112	45	82	70	10
5877	68-77	97	119	45	89	75	10
5884	75-84	105	127	50	96	75	10
5955	50-55	70	93	45	67	ns	10
5960	55-60	73	96	45	72	ns	10
5967	61-67	80	105	45	79	ns	10
5974	70-74	89	112	50	88	ns	10
5978	73-78	92	114	50	94	ns	10
5981	76-81	96	121	50	95	ns	8
5987	82-87	102	126	50	101	ns	8
5992	86-92	110	134	59	118	ns	12
5998	91-98	114	138	55	125	ns	10
59105	101-105	124	154	65	120	ns	12
59123	118-123	149	185	52	170	ns	12

ns – 59 series clamp fixing bolts supplied by customer.

Channel Mount – 58 Series

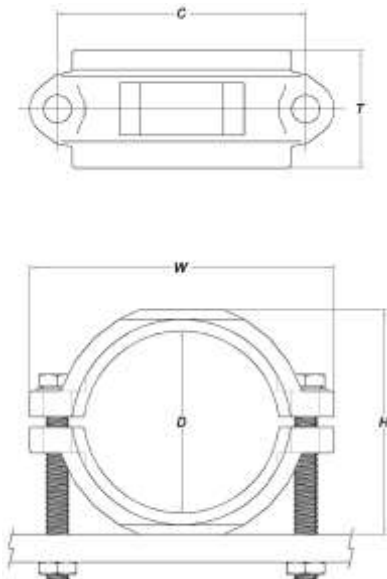

Surface Mount – 59 Series

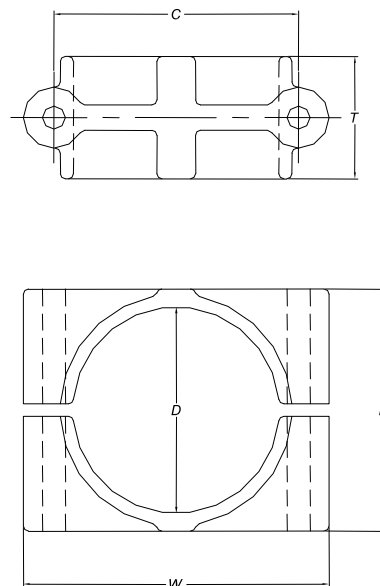

Neoprene Inserts (NI)

Neoprene Inserts Available. Add NI to Clamp No. e.g. 5870NI

Standard NI insert is 3mm thick. Other sizes are available upon request.

Cable OD range is reduced by 3mm i.e. 5870 range becomes 59-67mm

Special Clamps for Large OD Cables to 200mm +

Intertech has many different special clamps available and can also design clamps for specific purposes.

- ✓ Cast and fabricated special Cable clamps
- ✓ Cable size 100mmOD to 200mmOD+
- ✓ Cast Marine Grade Alloy
- ✓ High Strength
- ✓ Can be laboratory tested if required.
- ✓ Rapid production of non standard clamps for special purposes.
- ✓ Neoprene liners available.
- ✓ Epoxy/plastic surface coatings for corrosive environments.
- ✓ Special foot mounting allows angular adjustment for large cables.
- ✓ Side/flat mounting available

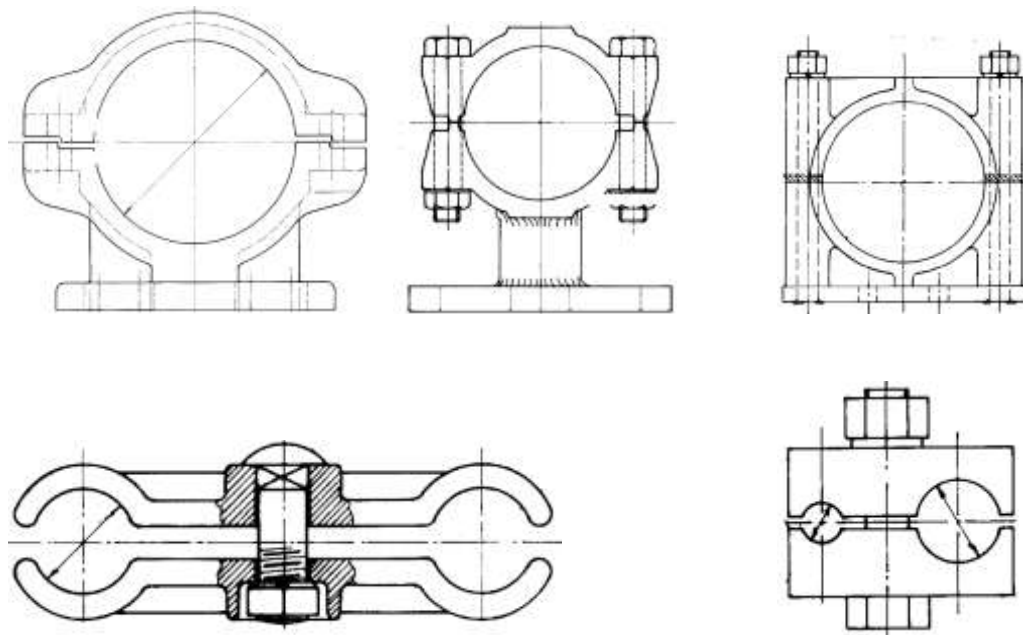

Atlantic Supports *Engineering* Ltd

GLASS REINFORCED COMPOSITE CABLE CLEATS

Manufactured from **ASEplas** high strength glass reinforced composite.

APPLICATION: To support medium and high voltage power transmission cables. Typically from 33kV to 500kV. Can be supplied with DTS cable slots.

USED ON:

- Cable systems for tunnels, bridges and masts
- Flexible (sag) and rigid cable systems
- Vertical shafts, sharps bends and cable joint bays
- Trefoil and single cable systems
- Cables with fibre optic sensors

MATERIAL PROPERTIES:

- Excellent thermal and electrical insulator with high dielectric strength.
- Corrosion free/zero maintenance.
- Zero Halogen/non toxic.
- Fire retardant/flame resistant/not easily ignitable.
- Resistant to UV and chemical attack.
- No significant water absorption.
- Fatigue tested to 10 million cycles.
- High physical strength in all directions.

PRODUCT BENEFITS:

- Non metallic therefore no problems with dissimilar metals when fixing to supporting structure or heat build up from magnetic field.
- Cost effective alternative to aluminium, does not require epoxy or other protective coatings.
- Robust and durable. Design life 40 years minimum.
- Strength checked using finite element method calculations supported by extensive laboratory testing.
- Resilient liner prevents cable damage due to movement and expansion; also allows for tolerance in cable diameters.



Atlantic Supports *Engineering* Ltd

GLASS REINFORCED COMPOSITE CABLE CLEATS

Type C

To support medium and high voltage power transmission cables, typically from 33 kV to 500 kV

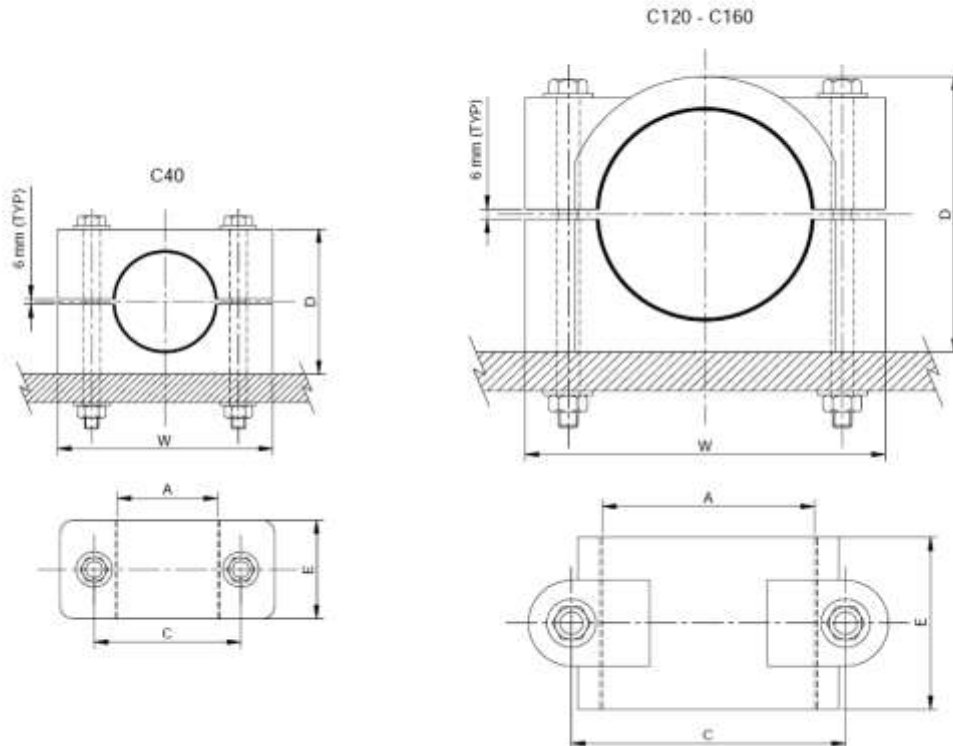

Part number	Cable diameter A	Bolt size	C	D	E	W	Safe working load kN	Short term load kN
C40/M8/*	20 to 40	M8x85	54	60	30	80	2	10
C120/M12/*	101 to 120	M12x200	156	160	100	205	10	50
C120/M16/*	101 to 120	M16x200	156	160	100	205	10	50
C130/M12/*	121 to 130	M12x200	164	170	100	215	10	50
C130/M16/*	121 to 130	M16x200	164	170	100	215	10	50
C140/M16/*	131 to 140	M16x200	174	180	100	225	10	50
C160/M16/*	141 to 160	M16x200	190	200	100	230	10	50

*Please specify outside cable diameter, A. (e.g. part number C120/M12/110 has an outside cable diameter of 110mm)

NOTES:

- Unless otherwise stated, all dimensions are in millimetres.
- Safe working load is applicable to a continuous load in any direction.
- Short term load is applicable to a short duration overload condition in any direction.
- The standard range loads are quoted at 25°C and should be derated linearly with temperature to 50% at +160°C.
- No reduction in strength occurs below +25°C.
- Cleats are constructed from **ASEplas** 1010 SWA glass reinforced composite material.
- Maximum initial torque for fixing bolts 20Nm.

Atlantic Supports *Engineering* Ltd

GLASS REINFORCED COMPOSITE CABLE CLEATS

– CHANNEL MOUNTED [U-TYPE]

To support medium and high voltage power transmission cables, typically from 33 kV to 500 kV

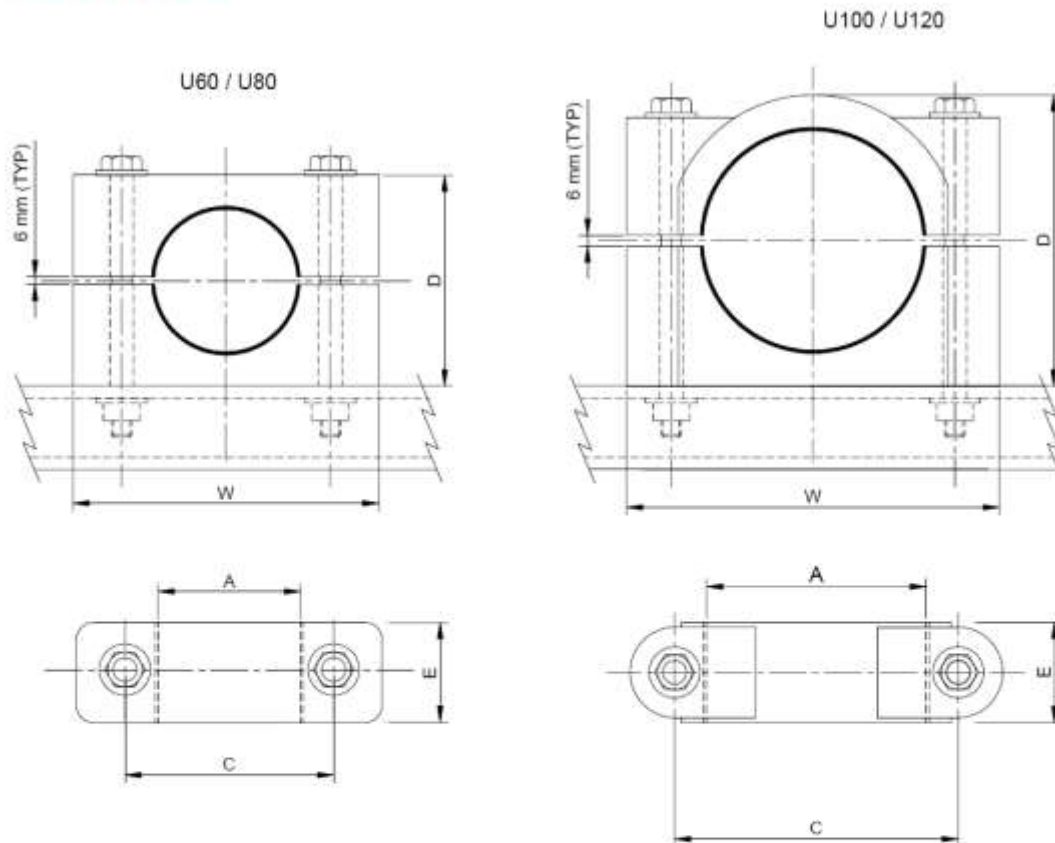

Part number	Cable diameter A	Bolt size	C	D	E	W	Safe working load kN	Short term load kN
U60/M10/*	41 to 60	M10x120	98	90	55	155	5	25
U80/M12/*	61 to 80	M12x160	114	115	55	167	5	25
U100/M12/*	81 to 100	M12x170	130	140	55	180	7	35
U120/M12/*	101 to 120	M12x200	156	160	55	205	7	35

*Please specify outside cable diameter, A. (e.g. part number U120/M12/110 has an outside cable diameter of 110mm)

NOTES:

- Unless otherwise stated, all dimensions are in millimetres.
- Safe working load is applicable to a continuous load in any direction.
- Short term load is applicable to a short duration overload condition in any direction.
- The standard range loads are quoted at 25°C and should be derated linearly with temperature to 50% at +160°C.
- No reduction in strength occurs below +25°C.
- Cleats are constructed from **ASEplus** 1010 SWA glass reinforced composite material.
- Maximum initial torque for fixing bolts 20Nm.

Atlantic Supports *Engineering* Ltd

GLASS REINFORCED COMPOSITE CABLE CLEATS – TREFOIL Type T

To support medium and high voltage power transmission cables, typically from 33 kV to 500 kV

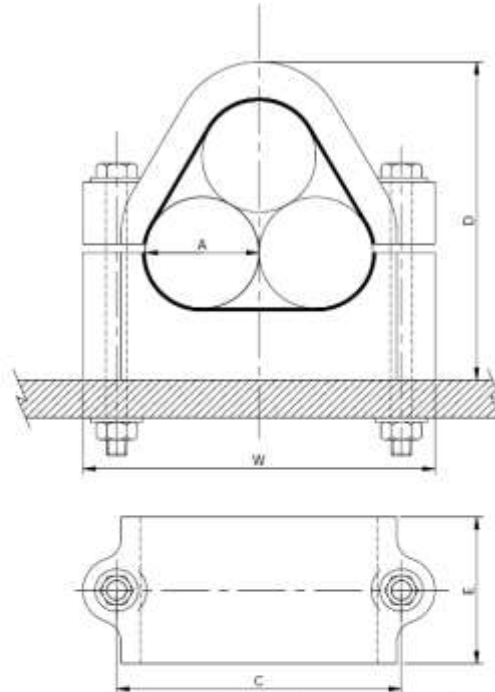

Part number	Cable diameter A	Bolt size	C	D	E	W	Safe working load kN **	Short term load kN **
T69/M12/*	66 to 69	M12x180	190	218	100	235	5	25
T76/M12/*	74 to 78	M12x180	190	218	100	235	5	25
T96/M16/*	91 to 97	M16x180	274	277	100	328	7	35
T100/M16/H*	98 to 105	M16x180	284	284	100	328	10	50
T106/M16/H*	104 to 107	M16x180	284	284	100	328	10	50
T107/M16/*	105 to 108	M16x180	274	277	100	328	7	35
T116/M16/H*	114 to 117	M16x180	284	284	100	328	10	50
T140/M16/H*	138 to 145	M16x215	365	366	100	410	10	50
T150/M16/H*	146 to 154	M16x215	365	366	100	410	10	50
T160/M16/H*	156 to 164	M16x235	385	386	100	435	10	50

*Please specify outside cable diameter, A, (e.g. part number T76/M12/76 has an outside cable diameter of 76mm)

NOTES:

- Unless otherwise stated, all dimensions are in millimetres.
- Safe working load is applicable to a continuous load in any direction.
- Short term load is applicable to a short duration overload condition in any direction.
- The standard range loads are quoted at 25°C and should be derated linearly with temperature to 50% at +160°C.
- No reduction in strength occurs below +25°C.
- Cleats are constructed from **ASEplus** 1010 SWA glass reinforced composite material.
- Maximum initial torque for fixing bolts 20Nm.

The KOZ Range of Cable Clamps are made from high strength glass-reinforced polyamide. This unique material provides excellent properties for Cable Clamps:

- Halogen free
- High Tensile Strength, ranging up to 40kN
- Excellent Heat Resistance, with no loss of mechanical strength over the temperature range of -40°C to +135 °C
- UV Resistant for outdoor applications
- Flame Retardant, tested to VDE 0304 Part 3
- Chemical Resistant



The KOZ range of clamps has been extensively tested by KEMA and UL. Tests covered include mechanical strength, short circuit strength, heat resistance, fire retardant properties.

Single way, trefoil and flat style clamps are available for cable diameters from 18 to 145mm.

KOZ Single Way Clamps – ST and STC

The ST and STC range of clamps are suitable for single and multi-core LV, MV and HV cables.

KOZ ST Clamps

The ST range have a flat base and flat top, allowing for easy stacking of the clamps in large installations. Fixing is by way of the two side clamping bolts.

Size	Cable OD (mm)	L (mm)	B (mm)	I (mm)	DØ (mm)	H (mm)	h (mm)	A (mm)	Weight (gm)
ST 18-26	18-26	77	45	49	10.5	36-44	13.5	6	90
ST 26-38	26-38	92	60	60	12.5	48-60	21	10	170
ST 36-52	36-52	108	60	75	12.5	58-74	27	11	225
ST 50-75	50-75	128	60	95	12.5	76-101	35	14	310
ST 75-100	75-100	169	80	127	14.5	110-135	51	19	815
ST 100-130	100-130	200	80	158	14.5	141-170	65	20	1000

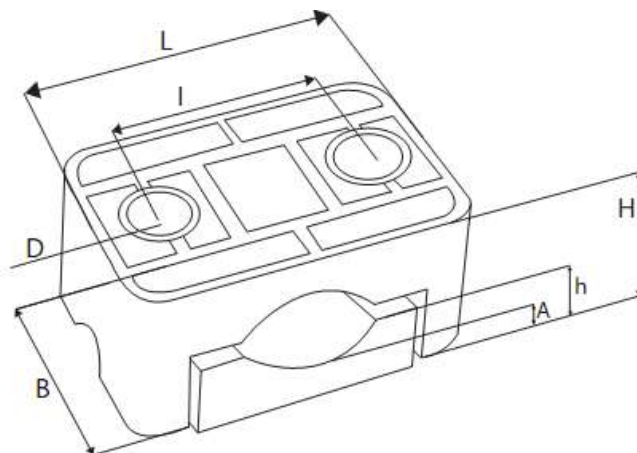
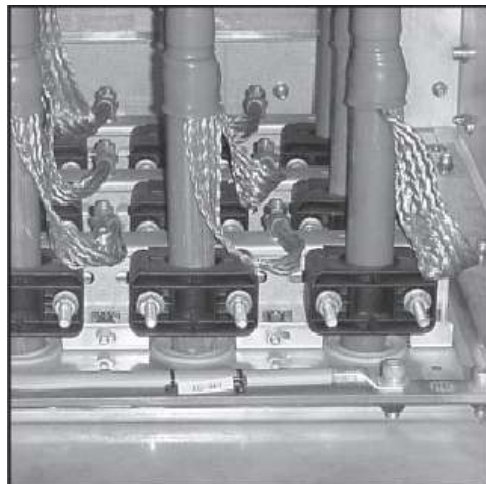
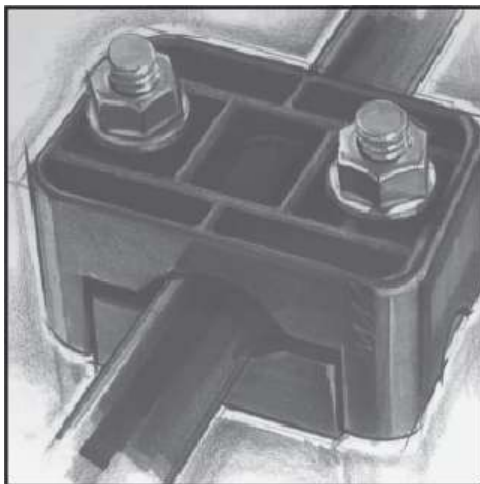

KOZ STC Clamps

The STC range has a central fixing hole in the base, allowing central or side fixing arrangements. The central fixing hole makes the clamp ideal of channel as well as surface mounting.

Size	Cable OD (mm)	L (mm)	B (mm)	I (mm)	DØ (mm)	H (mm)	h (mm)	A (mm)	Weight (gm)
STC 21-38	21-38	92	60	60	12.5	54-70	26	18	174
STC 36-52	36-52	107	60	75	12.5	69-84	33	18	237
STC 46-75	46-75	128	60	95	12.5	79-104	35	20	298
STC 72-100	72-100	172	80	127	14.5	90-115	51	22.5	768

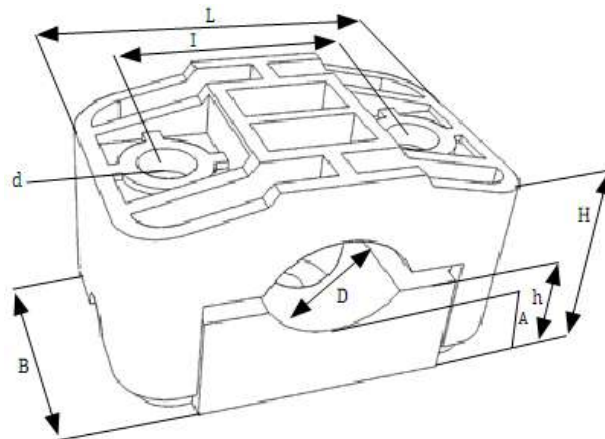
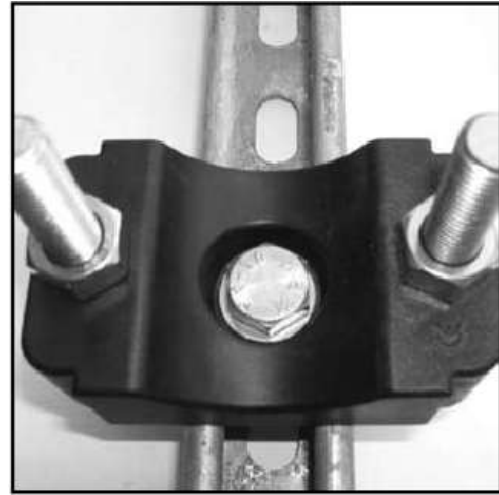
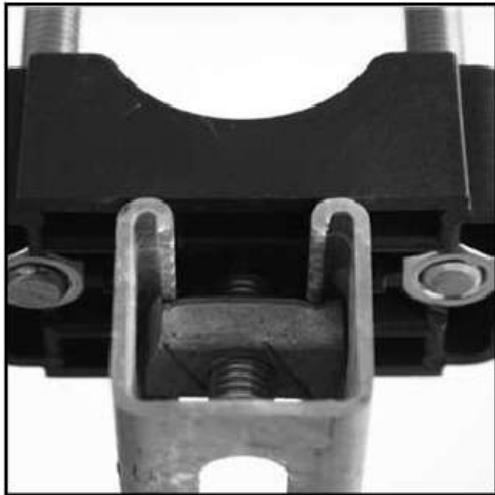

KOZ Trefoil Clamps – TRI

The TRI and TRI eco range of clamps are suitable for three single-core LV, MV and HV cables in a trefoil arrangement.

KOZ TRI Clamps

The TRI range have a flat base and a central fixing hole for either surface mounting or channel mounting.

The clamp is designed for high fault currents.

Size	Cable OD (mm)	L (mm)	B (mm)	I (mm)	dØ (mm)	H (mm)	h (mm)	A (mm)	Weight (gm)
TRI 25-40	25-40*	172	80	125	14.5	80-108	46	30	835
TRI 38-53	38-53	190	80	145	14.5	80-115	54	30	890
TRI 53-66	53-66	216	80	169	15	100-120	44	25	1120
TRI 67-82	67-82	252	100	202	16.5	140-175	70	26	1840
TRI 82-98	82-98	284	100	234	16.5	168-205	78	26	2515
TRI 99-120	99-120	342	115	288	19.0	155-203	88	33	3065
TRI 121-145	121-145	392	115	338	19.0	180-238	100	33	3607

*the TRI 25-40 clamp uses an insert for cables less than 29mm diameter

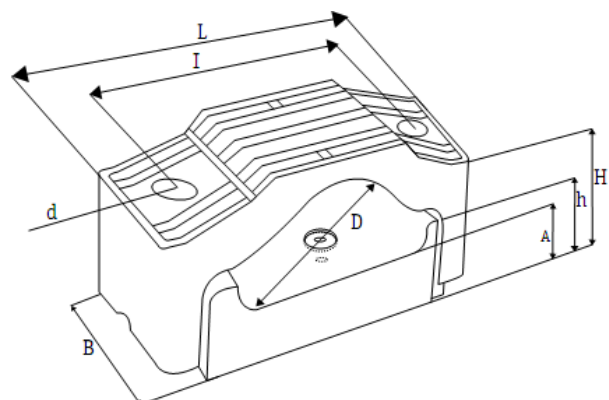
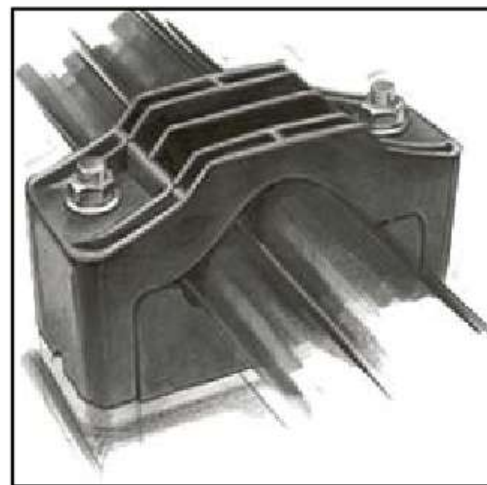

KOZ TRI eco Clamps

The TRI eco range are trefoil clamps designed for easy stacking. The clamp base has a recessed area to accommodate an adjacent clamp top. The eco design is for lower fault rating applications, up to 16.9kN

Size	Cable OD (mm)	L (mm)	B (mm)	I (mm)	dØ (mm)	H (mm)	h (mm)	A (mm)	C (mm)	Weight (gm)
TRI eco 24-35	24-35	136	70	101	11	54-78	35	20	40	315
TRI eco 33-46	33-46	156	70	121	11	58-90	41	20	50	385

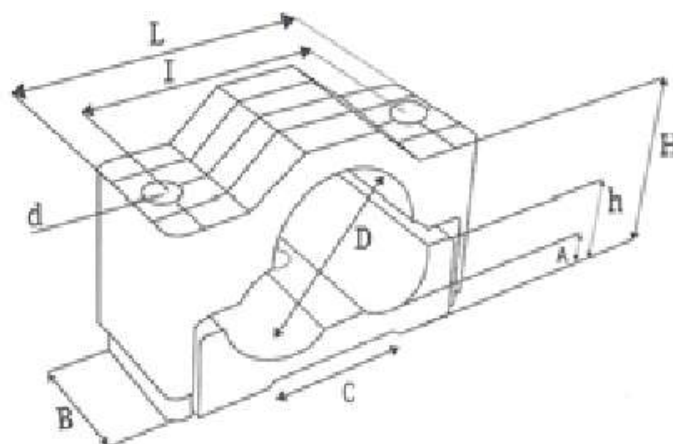
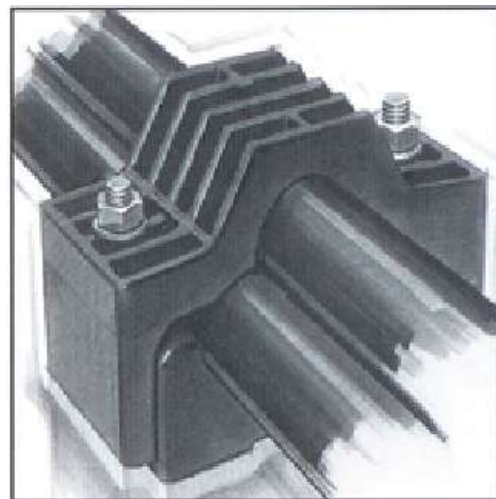

KOZ Mounting Blocks – UNI

The KOZ UNI system is designed for installations with large numbers of cables running together. The UNI system allows the cables to be installed in an organised and tidy configuration.

Size	Cable OD (mm)	A (mm)	B (mm)	C (mm)	D (mm)	E (mm)	G (mm)	H (mm)	I (mm)
UNI 3x13-32	13-32	186.5	32.25	60.5	62.75	60.5	43.0	45.0	61.0
UNI 4x13-32	13-32	246.5	32.25	60.5	62.75	60.5	43.0	45.0	61.0
UNI 4x30-47	30-47	345	44.5	85.0	87.5	85.0	65.0	50.0	66.0

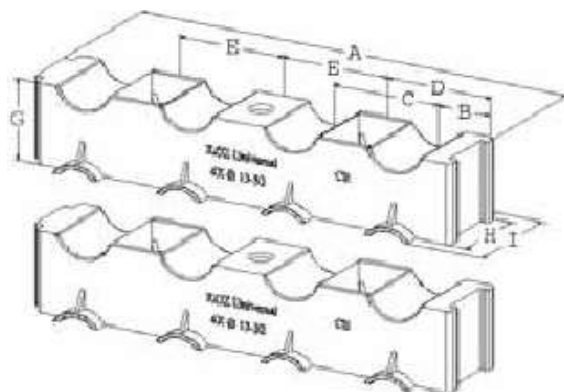

CABLE CLAMP SELECTION

When choosing a Cable Clamp, the following factors should be considered.

- Total mechanical load the clamp is expected to support.
- Type of installation, such as horizontal runs, vertical runs, complex routes
- Environmental conditions, indoor, outdoor, chemicals, salt-air etc.
- Operating temperature of the cables and the ambient temperatures.
- Material compatibility. i.e. the structure to which the clamp will be fixed.
- Cable overall size, shape and configuration (flat, trefoil etc)

CORRECT SPACING

The following is the recommendations of IEE Wiring regulations for clamp spacings for single cables up to 40mm in diameter, and typical industry recommendations above 40mm diameter.

SPACING OF SUPPORTS ON SINGLE CABLES						
Overall Diameter of Cables	Non-armoured rubber, PVC or lead sheathed cables		Armoured cables and corrugated aluminium sheathed cables		Mineral Insulated Cables	
	Horizontal	Vertical	Horizontal	Vertical	Horizontal	Vertical
≤9mm	250	400	-	-	600	800
9≤15mm	300	400	350	450	900	1200
15≤20mm	350	450	400	550	1500	2000
20≤40mm	400	550	450	600	-	-
40≤50mm	600	800	900	1100	-	-
50≤60mm	750	1000	950	1100	-	-
60≤70mm	900	1200	1000	1200	-	-
>70mm	1000	1400	1200	1400	-	-

CLAMP QUOTATION REQUEST FORM

PLEASE COPY, COMPLETE THE DETAILS AND FAX TO: INTERTECH ENGINEERING

Your Name:..... Your Company:.....

Contact Details:

Tel..... Fax..... Email.....

CABLE & RUN DETAILS

RUN ()

CABLE OD (mm) Run Length (m) Single cable? Y/N

Trefoil cable? Y/N Other Grouping? Quad/ Parallel etc

Cable Voltage or Data Cable? Operating Temp

Cable Type Cable System fault Rating kA

Cable run Horizontal/Vertical Cable fixed to
(e.g. solid base, Unistrut, Ladder, Pole)

Location: Inside/Outdoor/Mixed.....

Environment: Corrosive/ High temperature etc.....

Contact details



Intertech Engineering Pty Ltd

Head Office and Factory:

15, Sir Laurence Drive, Seaford, Victoria 3198
PO Box 2117, Seaford DC, VIC 3198
Phone: 03 8770 5500 **Fax:** 03 9773 5666
email: sales@intertecheng.com.au

Sydney Office:

8/79 Williamson Road
INGLEBURN, NSW 2565
PO Box 5086 MINTO BC NSW 2566
Phone: 02 9605 7648 **Fax:** 02 9605 7951
email: sales@intertecheng.com.au

Brisbane Office

11/720 Macarthur Avenue Central
Pinkenba QLD 4008
Phone: 07 3260 1369 **Fax:** 07 3260 1394
email: sales@intertecheng.com.au

www.intertech-eng.com.au

rev 4.1 Jan 2012